

# Global-Tek Machinery Pte Ltd

## Double-Tank Conveyor Type

### Dish Washing Machine

#### Model - GT-CR2

#### Instruction & Installation Manual

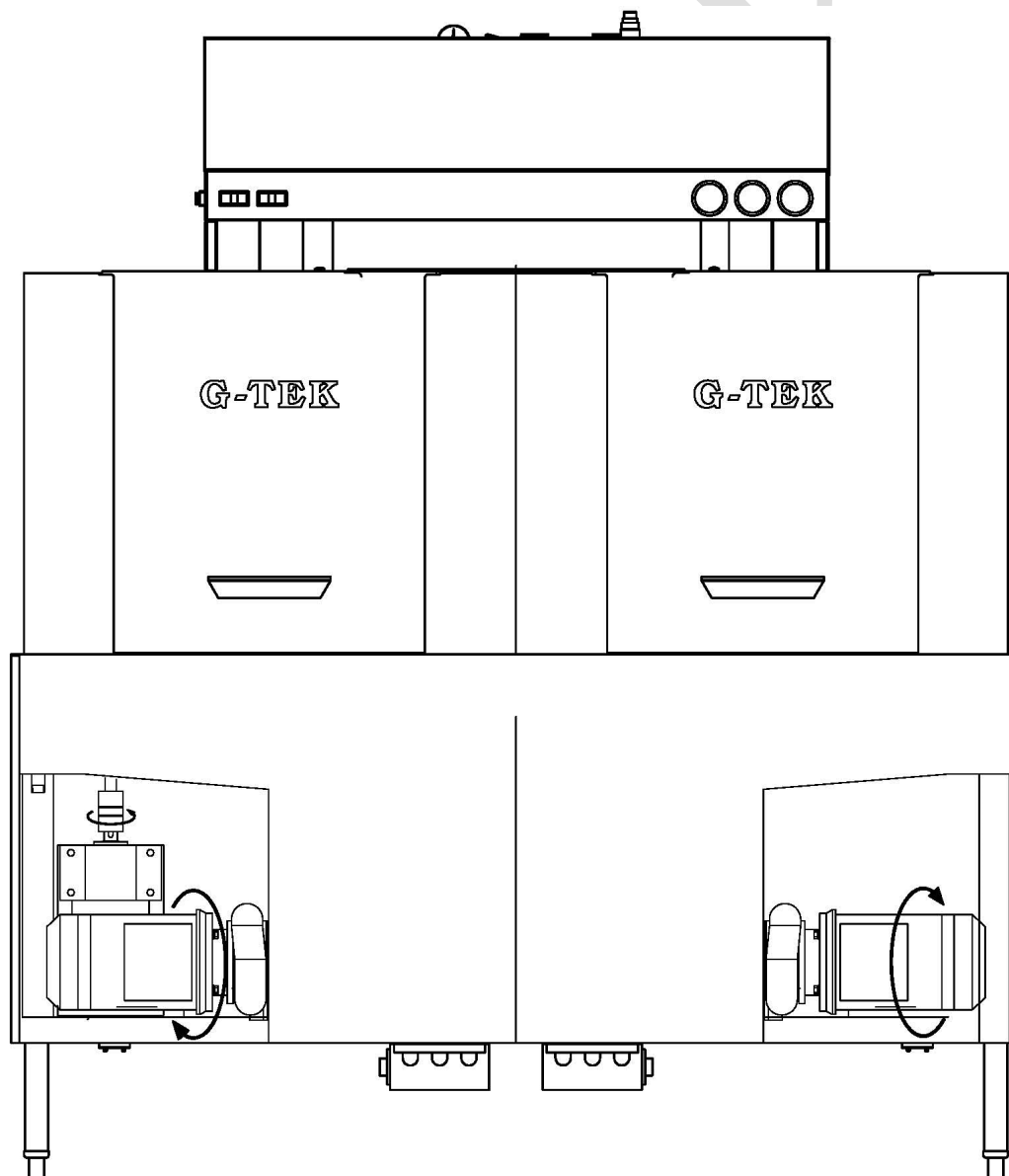

# Global-Tek Machinery Pte Ltd

## CONTENTS

<b>GENERAL.....</b>	<b>3</b>
Technical Data.....	3
Standard Equipment.....	4-6
<b>INSTALLATION.....</b>	<b>7</b>
Unpacking.....	7
Assembly.....	7
Plumbing Connections.....	7
Drain Connections.....	7
Fill Connection.....	8
<b>ELECTRICAL CONNECTIONS.....</b>	<b>8-9</b>
<b>OPERATION.....</b>	<b>9-10</b>
Preparation.....	9-10
Operating The Machine.....	10
<b>CLEANING.....</b>	<b>11</b>
<b>MAINTENANCE.....</b>	<b>12</b>
<b>TROUBLESHOOTING.....</b>	<b>13-15</b>
<b>CIRCUIT DIAGRAMS.....</b>	<b>16-18</b>

# Global-Tek Machinery Pte Ltd

## Model : GT-CR-2

### GENERAL

GT-CR2 Dishwasher is a fully automatic, rack-type double-tank conveyor machine. It has two stainless tanks and chambers with welded stainless steel angle frame, stainless steel legs, and stainless steel adjustable feet. Front inspection doors provide ready access to the interior of the wash chambers. This machine has 4 x 9 kW booster heater, and is available with either steam or electric heat supply.





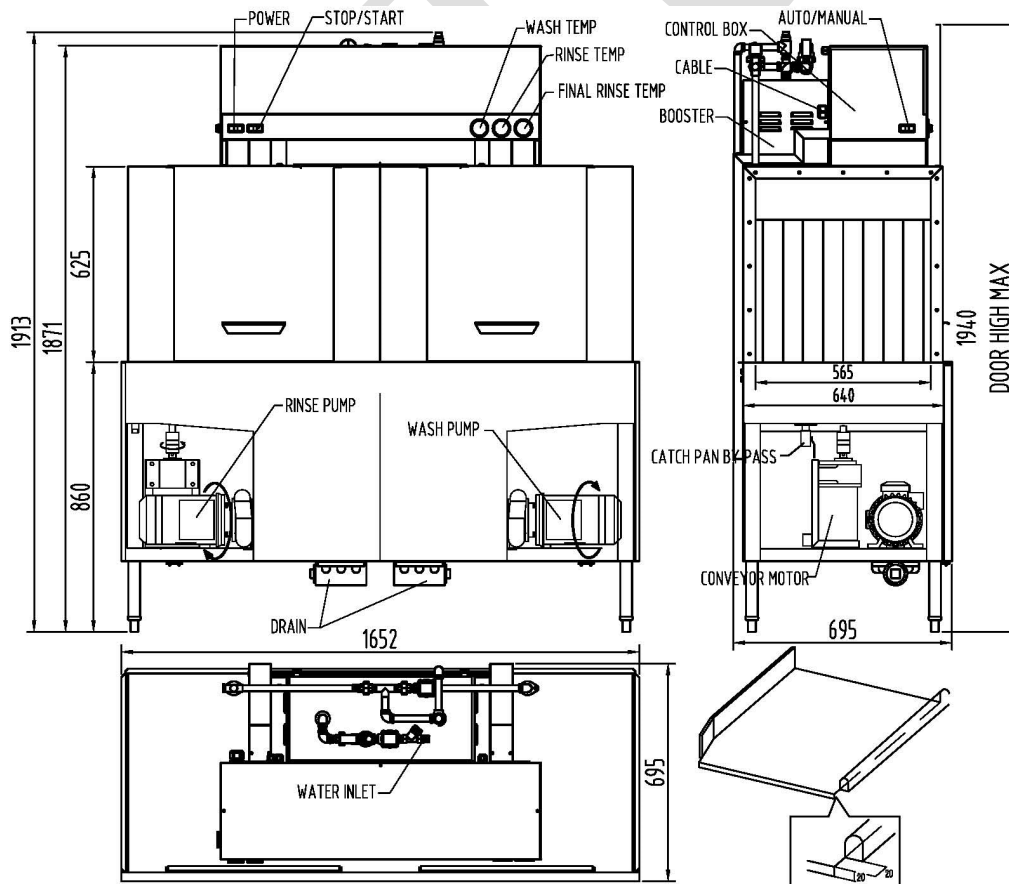

### TECHNICAL DATA

Dimensions (W x D x H)	:	1652mm x 695mm x 1890mm
Maximum Capacity (racks/hour)	:	268
Max height for washing	:	450mm
Tank heat	:	7.5 Kw x 2
Total power supply (Kw)	:	54 Kw
Water consumption/hour (L)	:	536 L
Water consumption/rack (L)	:	2 L



# Global-Tek Machinery Pte Ltd

## STANDARD EQUIPMENT

The control panel and booster are mounted on the top of the chamber. There are three operational control switches housed in the control panel: POWER  (ON -OFF ); MOTOR  (START -STOP );and TIMER (MANUAL -AUTO ).

Mechanical thermostat for wash & rinse tanks are located outside the tank, final rinse thermostats are located inside the control panel. Suggested temperature range for wash is 55-65°C, rinse is 65-70°C and for final rinse is 82-95°C.

### Motor and Pump Units

The 2-horsepower wash motor and pump are centrifugal-type cast stainless steel with stainless steel impeller.

Motor is available in the following voltages:

<u>Volts</u>	<u>Hz</u>	<u>Phase</u>
380	50	3

The conveyor motor is a 0.24 Kw gear motor with the same voltage as the wash pump motor with built-in overloaded protection system.

### Clutch/Rack Transport Protection

The conveyor motor transfers power to the rack transport system through the clutch. When the machine is overloaded or the racks jam the clutch sends a signal to stop the conveyor motor to protect the machine, rack transport mechanism and motor.

### Heater Protection

A float switch located in the wash tank automatically turns off the heat supply if the water level is too low. Once the water returns to a required level, the heating circuit becomes operational if heat is demanded.

# **Global-Tek Machinery Pte Ltd**

An over-heat protector is also provided for electric heater. If overheating occurred, the heat supply will be turned off. Turn the POWER switch OFF and contact your authorized service office.

## **Booster Protection**

The booster water temperature is regulated by two thermostats to keep the rinse water temperature between 82-95°C. The thermostats are preset at the factory and no adjustment is needed. If necessary, contact your local authorized service office.

**WARNING:** The breaker is preset to “OFF” at the factory. Do not turn on the breaker until all the tanks and boosters filled with water by activating the machine auto fill. **Only** turn the breaker on after all tanks are filled, otherwise, the booster tank & its heating elements will be damaged!!

## **Rinse Booster**

Booster heater is equipped with 4 x 9 Kw heating elements.

## **Wash/Auto-timer Actuator and Rinse Actuator**

Wash actuator, which is located at the entrance of the machine, works only when the timer is turned to AUTO. When the rack enters the machine, wash begins. When timer is on MANUAL the switch does not function.

The rinse actuator is located at the exit of the machine. Rack contact with the rinse actuator activates the final rinse.

## **Door Interlock**

Door interlock switches will prevent machine operation while an inspection door is open during the machine is operating, the wash motors and conveyor motor will automatically turn off. After the door is closed, the machine must be restarted by pushing the MOTOR switch to ON.

# **Global-Tek Machinery Pte Ltd**

## **Wash/Rinse Arms**

Wash and rinse arms are removable for daily cleaning purpose.

## **Auto Fill**

Close all doors and push the POWER switch to ON. The machine fills automatically from two different areas, final rinse & fill valve. Water is pre-heated in booster and flows into wash & rinse tanks. After the tanks are filled with required level, fill will stop automatically.

## **Auto Timer**

The Auto Timer switch is located on the left-hand side of the control box. Designed to save electrical power, it is adjusted to shut off pump and drive motors and optional exhaust vent fan control after the last rack exits the dishwasher. To restart, slide a rack into the machine or push MOTOR switch to ON. To change the time setting, contact your local authorized service office.

## **Front Panel**

Stainless steel front panel conceals motors, pumps, and plumbing.

## **Common Water Connection**

A single water connection for Fill and Final Rinse is standard. Maximum feed temperature to the machine is 65C with 15 - 20 psi incoming water pressure. **Excess water pressure or temperature will cause damage to booster heater tank.**

# Global-Tek Machinery Pte Ltd

## INSTALLATION

### UNPACKING

Immediately after unpacking the dishwasher, check it for possible shipping damage. If this machine is found to be damaged after unpacking, save the packaging material, and contact the carrier within 3 days from date of delivery.

Prior to installation, verify that the electrical service agrees with the specifications on the machine data plate, which refer to the operation and services manual

After unpacking the dishwasher, remove the items shipped uninstalled (overflow tube, pump intake strainer, curtains, and chamber hole plug kit) and instruction manual inside the machine. Set the dishwasher in its proper location. Adjust the height and level by turning the adjustable feet. NOTE: The dishwasher must be positioned and leveled before making plumbing connections.

### ASSEMBLY

Dish tables should be fitted into the dishwasher. Use Mastic between table and lip of tank to prevent leakage. Rack track height should be from 4 mm to 6 mm above the tank lip. Dish tables should be sloped so that any water carried from the dishwasher will drain back into it.

### PLUMBING CONNECTIONS

**WARNING:** PLUMBING CONNECTIONS MUST COMPLY WITH APPLICABLE SANITARY, SAFETY, AND PLUMBING CODES.

The plumber who connects this machine is responsible for making certain that both water and steam lines are THOROUGHLY FLUSHED OUT BEFORE connecting to any manual valve or solenoid valve.

Manual valves or solenoid valves fouled by foreign matter, and any expenses resulting from this fouling, are NOT the responsibility of the manufacturer.

# Global-Tek Machinery Pte Ltd

## DRAIN CONNECTION

Connect the drain through a trap to the sewer pipe.

## FILL CONNECTION

Use pipe for the connecting line. The flowing pressure is preset 1.4kg/cm<sup>2</sup>. Water flows into booster and is heated, then into wash tank. After the tank is filled, the float-controlled high-water switch closes the solenoid valve. If during the operation water level in wash tank is lower than the required water level, fill solenoid valve will be opened to top-up the tank.

**WARNING:** Do not operate the machine when flowing pressure is under 1.0 kg/cm<sup>2</sup>. Low pressure may result in inadequate rinsing. The water fill connection must be 65°C maximum and flow pressure should not exceed 16kg/cm<sup>2</sup>, otherwise, the pressure regulator valve will be damaged. This regulator is preset at the factory and no adjustment should be required.

## ELECTRICAL CONNECTIONS

### Power connection

Power connection is housed in the control box.

**NOTE:** Three power lines must connect to L1/L2/L3 of the junction line, and neutral line connects to neutral line terminal block (neutral line is not required for this machine). Earth line must be connected to the terminal block provided.

**WARNING:** PRIOR TO CONNECTION, VERIFY THAT THE ELECTRICAL SERVICE AGREES WITH THE SPECIFICATIONS OF THE MACHINE, WHICH IS REFER TO THE OPERATION AND SERVICES MANUAL, POWER LINE MUST COMPLY WITH THE CURRENT ON THE MACHINE DATA.

**WARNING:** ELECTRICAL AND EARTH CONNECTION MUST COMPLY WITH THE APPLICABLE PORTIONS OF THE NATIONAL ELECTRICAL CODE ANSI/NFPA 70 (LATEST EDITION) AND/OR OTHER LOCAL ELECTRICAL CODES.

**WARNING:** DISCONNECT ELECTRICAL POWER SUPPLY AND PLACE A TAG AT THE DISCONNECT SWITCH TO INDICATE THAT YOU ARE WORKING ON THE CIRCUIT.



# Global-Tek Machinery Pte Ltd

Some machines may have more than one electrical power supply. All supplies must be disconnected.

## Motor(s)

Connect a permanent electrical power supply to the terminal block in the control box. Three-phase motor rotate the impeller in the direction of the arrow found on the pump housing of the motor pump unit, and the drive motor must rotate clockwise when viewed from the output shaft end. Before placing the machine into service, a check must be made to verify correct rotation. Only one motor needs to be checked as the machine is wired at the time of manufacture so that all motors will rotate the same direction.

If the impeller does not rotate in the direction of the arrow, DISCONNECT POWER SUPPLY to the machine and interchange any two power supply leads at the control box terminal block. Or machine with a circuit breaker, reverse any two leads at the incoming power supply block in the circuit breaker (three-phase only). Start the machine momentarily and verify proper direction of rotation.

**WARNING:** Circuit breakers for booster heater have been switched off before machine leaving factory to avoid dry operation of the booster elements. **SWITCH ON CIRCUIT ONLY AFTER THE FOLLOWING PROCEDURE.** Position and level the dishwasher; connect electrical power, water inlet and drainpipe. Turn on the power switch; solenoid valve is activated to fill the machine. When the tanks are full, both circuit breakers for booster heater can be switched on now. **Failure to follow this procedure can result in machine manage.**

## OPERATION

### PREPARATION

Put the dishwasher strainer pans and strainer basket into position in each tank. Put the final rinse screen over the final rinse catch pan.

Hang curtains on open hooks provides to your machine. **Be sure long & short curtains are located correctly.**

Close the drain valve at the bottom of the machine and close the door.

Turn POWER switch ON. The pump should be left OFF until the machine has filled.

Temperature requirement for machine is:

# Global-Tek Machinery Pte Ltd

## 1<sup>st</sup> Tank

## 2<sup>nd</sup> Tank

## Final Rinse

55-65°C (130-150<sup>0</sup>F)

65-70°C(150-160<sup>0</sup>F)

82-95°C(180-198<sup>0</sup>F)

If the tank is accidentally drained before turning off the power switch, the float-controlled low-water protector switch will automatically stop the tank heat. When the proper water level is returned, the tank heat will be automatically started. **DO NOT** use the low-water protection as a power **ON-OFF** switch. The heat **MUST** be turned **OFF** at the **POWER** switch when the machine is not in use.

Scatter the initial charge of detergent on the dishwasher strainer pans. Replenish as needed. When an automatic detergent dispenser has been added (by private supplier), follow supplier's instructions.

## Operating The Machine

After machine has filled, start pumps by pushing MOTOR switch to ON.

Stack dishes in the racks. Do not stack dishes one on top of each other, as water must have free access to both sides of every dish. Stand plates and dishes up edgewise. cups, glasses, and bowls should be inverted in open-type or compartment-type rack, silverware and other small pieces may be scattered loosely over the bottom of a flat-bottom rack.

When a rack has been loaded, slide it into the machine and start loading another. The operation of the dishwasher is automatic. Each rack moves through the wash, and rinse zones, then out onto the clean dish table. The rinse lever is activated by the dish rack and automatically shuts off the final rinse water when no rack is in the rinse zone.

Allow dishes to drain and air-dry before removing from rack.

An overload mechanism namely limit switch (near the conveyor motor) is provided that will shut off the conveyor drive motor should the racks jam or the load becomes excessive. After the jam is cleared, push the MOTOR switch to NO to restart the dishwasher.

## CLEANING

1. Turn MOTOR and POWER switches OFF.
2. Open the door. Standard door interlock switches prevent machine operation with inspection door open.

# Global-Tek Machinery Pte Ltd

3. Open drain by turning drain valve.
4. Check the upper and lower final rinse nozzles, or auxiliary rinse nozzles (if so equipped) to make sure they are free of lime and solids.  
If the nozzles are clogged, open them by poking a straightened-out paper clip into the opening. Unscrew and remove the rinse arm end cap and, with the splash curtains in place and the machine door closed, run an empty rack through the dishwasher as in normal operating procedure.  
When the rack exits, open the machine door, and replace the end cap.
5. Remove wash arms. Thoroughly flush the wash arm in a sink and replace the wash arm end caps (a twisting action helps ensure proper seating).
6. Clean off any scraps from machine walls.
7. Clean dish tables into the dishwasher.
8. Remove all strainer pans and strainer basket(s). Empty contents into garbage can or disposer and thoroughly clean pans and basket(s).
9. Remove and clean pump intake strainer.
10. Remove final rinse pan strainer. Clean out pan and drain opening in pan bottom. Clean off strainer.
11. Remove curtains. Thoroughly scrub, rinse, and allow to dry at the end of each day's operation. See appropriate curtain for proper curtain installation.
12. THOROUGHLY wash out the interior of the machine with a high-pressure hose.
13. Return all strainer pans, strainer basket(s), and pump intake strainer to original locations.
14. Install upper wash arms. Rest the manifold on the rear hanger bracket with the open end of the arm next to the wash pipe and rotate the arm upward to latch it.
15. Insert the lower wash arm at an angle between the conveyors and install the retainer over the pin. Rotate the arm toward the catch and engage the hook into the notch.
16. Leave door open and curtains removed while machine is not in use. This will allow the interior to air out and dry.

## MAINTENANCE

**WARNING:** DISCONNECT ELECTRICAL SUPPLY AND PLACE A TAG AT THE DISCONNECT SWITCH TO INDICATE THAT YOU ARE WORKING ON

# **Global-Tek Machinery Pte Ltd**

THE CIRCUIT BEFORE BEGINNING ANY MAINTENANCE PROCEDURE.

Some machines may have more than one electrical power supply. All supplies MUST be disconnected.

**WARNING:** Disconnect Hi-Limit protector circuit when repairing booster. After service completed, connect Hi-Limit protector until the machine has filled. Failure to follow this procedure can result in damage to booster.

## **VENT**

When cool, check the vent (if installed) of this dishwasher every six months for obstructions.

## **MOTOR LUBRICATION**

None required.

## **TROUBLESHOOTING**

**NOTE:** if symptom persists after possible causes have been checked, contact your authorized service office.

# Global-Tek Machinery Pte Ltd

SYMPTOM	POSSIBLE CAUSES
No Machine Operation	<ol style="list-style-type: none"> <li>1. Blow fuse or tripped circuit breaker at power supply.</li> <li>2. Conveyor may be jammed.</li> <li>3. If Auto Timer was used, the timer may have expired.</li> <li>4. If table limit switch is used, the switch may be tripped.</li> <li>5. Manual overload protector tripped on pump motors or conveyor motors.</li> <li>6. Make sure door is closed.</li> <li>7. Door interlock switch may be damaged.</li> <li>8. Contactor for rack transport requires service.</li> <li>9. The clearance between clutch and sensor requires adjustment. The clearance should be 2-4mm.</li> </ol>
Dishes Not Clean	<ol style="list-style-type: none"> <li>1. Insufficient wash water due to drain obstruction preventing proper drain closing.</li> <li>2. Drain valve allowing wash water to drain.</li> <li>3. Missing end plug from wash arm.</li> <li>4. Wash arm nozzle obstruction.</li> <li>5. Water leaking past manifold “o” ring.</li> <li>6. Loss of water pressure due to pump obstructions.</li> <li>7. Incorrect water temperature. Check circuit breaker to electric heat supply, or main steam valve. Make certain valve is completely open.</li> <li>8. Incorrect detergent dispensing. Contact your detergent representative.</li> <li>9. Loss of water in the tank. Check the connection between overflow tube or steam valve.</li> </ol>
Leaking Valve (Except Solenoid Type) supplied by Others.	<ol style="list-style-type: none"> <li>1. Foreign material preventing proper valve operation. A critical period is soon after installation when pipe compound or metal shavings may lodge at the valve seat. Shut off supply line. Unscrew and lift bonnet from valve body. Clean valve and reassemble.</li> <li>2. If problem is with a solenoid valve, please contact your local Global Tek-authorized service office.</li> </ol>
Inadequate Rinse	<ol style="list-style-type: none"> <li>1. Dirty line strainer causing reduced water flow. Turn off water supply, remove strainer cap, withdraw, and clean screen. Reassemble.</li> <li>2. Low supply pipeline line pressure.</li> <li>3. Clogged rinse nozzle(s).</li> </ol>
Spotting of Silverware, Glasses, and Dishes	<ol style="list-style-type: none"> <li>1. Improperly loaded racks.</li> <li>2. Incorrect final rinse water temperature 82 °C (180<sup>0</sup> F)</li> </ol>

# Global-Tek Machinery Pte Ltd

	<p>minimum.</p> <ol style="list-style-type: none"> <li>Loss of water pressure due to pump obstruction. <b>DISCONNECT ELECTRICAL POWER SUPPLY AND PLACE A TAG AT THE DISCONNECT SWITCH TO INDICATE YOU ARE WORKING ON THE CIRCUIT.</b> Drain tank(s) and check for any obstruction at the pump intake.</li> <li>Clogged wash arm nozzles.</li> <li>Excessively hard water.</li> <li>Incorrect detergent for water type.</li> <li>Clogged rinse nozzle(s).</li> <li>Misaligned rinse arms. Rinse arms should be positioned so that the spray pattern is slightly toward the center of the dishwasher. <b>NOTE:</b> All machines may have alignment studs on the rinse arms that correspond to studs on the rinse piping.</li> </ol>
Continuous Rinse Operation	<ol style="list-style-type: none"> <li>Rinse actuator not moving freely. <b>DISCONNECT ELECTRICAL POWER SUPPLY AND PLACE A TAG AT THE DISCONNECT SWITCH TO INDICATE YOU ARE WORKING ON THE CIRCUIT.</b> Check actuator for movement.</li> <li>Check for foreign object in mechanism, i.e., silverware.</li> <li>Rinse valve failed or jammed open. Contact your local Global Tek-authorized service office.</li> </ol>
No Wash Tank Heat or Rinse Tank Heat	<ol style="list-style-type: none"> <li>The machine is equipped with low water safety devices which shut off heat if water level drops. Check for proper water level.</li> <li>Circuit breaker to heat system tripped.</li> <li>Check heat float for debris and free movement.</li> <li>Steam supply valve does not open completely.</li> <li>Over-temp protector tripped. Contact your local Global Tek-authorized service office.</li> </ol>
No or Slow Fill	<ol style="list-style-type: none"> <li>Dirty line strainer causing reduced water flow. Turn off water supply, remove strainer cap, withdraw, and clean screen. Reassemble.</li> <li>Make sure doors are closed.</li> <li>Check interlock switch.</li> <li>Check both upper and lower fill floats for debris and free movement.</li> </ol>

# Global-Tek Machinery Pte Ltd

	5. Problem with solenoid valve.
No Booster Heat or low water temperature	<ol style="list-style-type: none"> <li>1. Check the solid-state thermostat and probe.</li> <li>2. Check Hi-Limit protector.</li> <li>3. Circuit breaker to heat system tripped.</li> <li>4. Is contactor closed or coil damaged?</li> <li>5. Heater failure</li> <li>6. Check the water pressure regulator and water pressure.</li> </ol>
Overheat temperature in booster	<ol style="list-style-type: none"> <li>1. Low water pressure.</li> <li>2. Loss of water pressure due to pump filter in pump inlet pipe and output pipe.</li> <li>3. Clogged rinse nozzles.</li> <li>4. Check the solid-state thermostat and probe.</li> </ol>

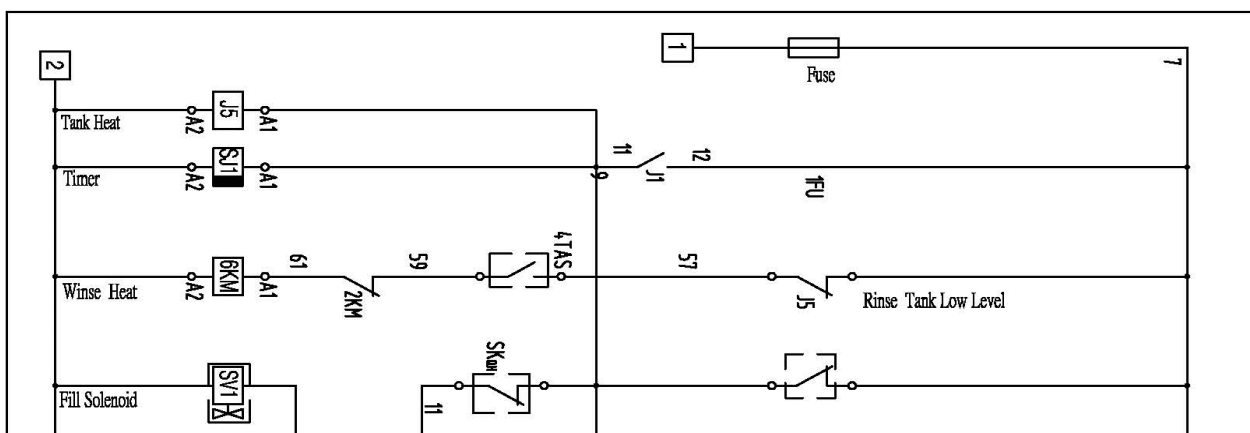

# Global-Tek Machinery Pte Ltd

Global-Tek

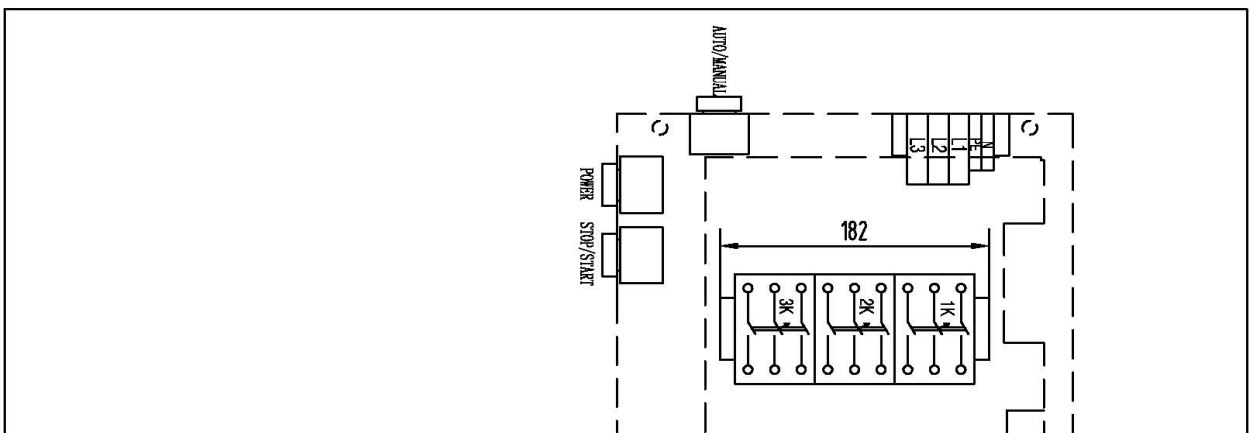



# Global-Tek Machinery Pte Ltd

Global-Tek

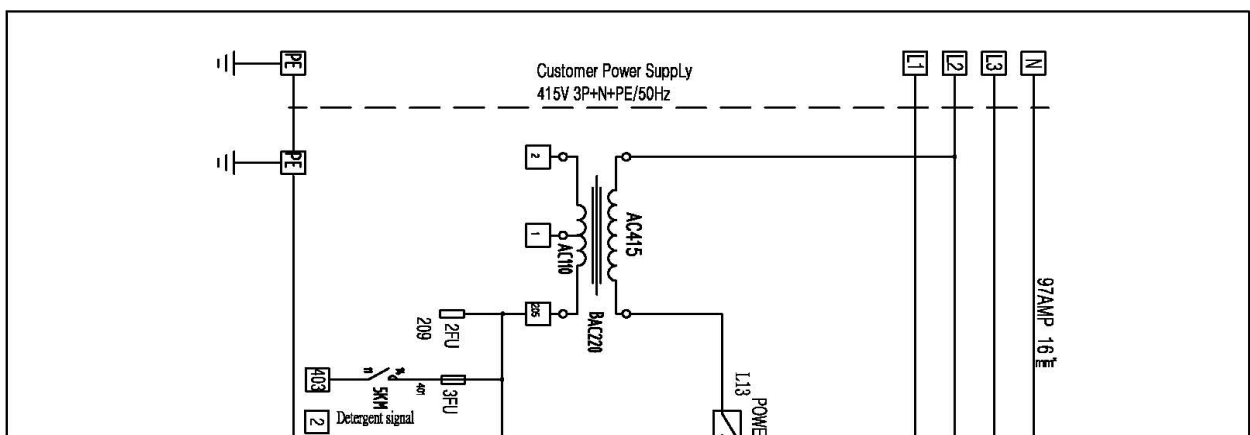

# Global-Tek Machinery Pte Ltd

## DISCLAIMER

Global-Tek Machinery Pte. Ltd. and/or Global-Tek Machinery Sdn. Bhd. and/or PT. Global Tek Indo and/or Global-Tek Technology (Shanghai) Co., Ltd. and/or Shanghai Global-Champion Machinery Co. Ltd does not accept responsibility for the mishandling, misuse, or non-performance of the described items when used for purposes other than those specified in the instructions. Products/machines/parts from Global-Tek Machinery Pte. Ltd., and/or Global-Tek Machinery Sdn. Bhd. and/or PT. Global Tek Indo, and/or Global-Tek Technology (Shanghai) Co., Ltd. and/or Shanghai Global-Champion Machinery Co. Ltd. are not for use in potentially explosive environments. Any use of our equipment in such an environment is at the risk of the user, Global-Tek Machinery Pte. Ltd. and/or Global-Tek Machinery Sdn. Bhd. and/or PT. Global Tek Indo and/or Global-Tek Technology (Shanghai) Co., Ltd. and/or Shanghai Global-Champion Machinery Co. Ltd. does not accept any liability in such circumstances.

## WARRANTY

Global-Tek Machinery Pte. Ltd. and/or Global-Tek Machinery Sdn. Bhd. and/or PT. Global Tek Indo and/or Global-Tek Technology (Shanghai) Co., Ltd. and/or Shanghai Global-Champion Machinery Co. Ltd. warranted against defects in material and workmanship for a period of **TWELEVE (12) months** from date of machine shipped, **THREE (3) months** warranty for parts sold separately. Warranty applies only to the replacement or repair of such parts when returned to factory with a given reference number, freight prepaid, and found to be defective upon factory authorized inspection. Bearings and pump seals or rubber and synthetic rubber parts such as “O” rings, diaphragms, and gaskets are considered expendable and are not covered under warranty. Warranty does not cover liability resulting from performance of this equipment nor the labor to replace this equipment. Product abuse or misuse voids warranty.

# **Global-Tek Machinery Pte Ltd**

## **FOOTNOTE**

The information and specifications included in this publication were in effect at the time of approval for printing. Global-Tek Machinery Pte. Ltd., and/or Global-Tek Machinery Sdn. Bhd. And/or PT. Global Tek Indo and/or Global-Tek Technology (Shanghai) Co., Ltd. and/or Shanghai Global-Champion Machinery Co. Ltd. reserves the right, however, to discontinue or change specifications or design at any time without notice and without incurring any obligation whatsoever.

### **Global-Tek Machinery Pte. Ltd.**

Tel: + 65 6749 7123

Fax + 65 6481 7123

e-mail : [info@global-tek.sg](mailto:info@global-tek.sg)

Website : [www.global-tek.sg](http://www.global-tek.sg)

### **Global-Tek Technology (Shanghai) Co., Ltd.**

Tel : + 86 6978 8878

HP + 86 1370 173 3517

e-mail. [thomas.teng@global-tek.org](mailto:thomas.teng@global-tek.org)

Website : [www.global-tek.sg](http://www.global-tek.sg)

### **Global Tek Machinery Sdn. Bhd.**

Tel: + 60 12 925 5388

e-mail : [justin@global-tek.sg](mailto:justin@global-tek.sg)

Website : [www.global-tek.sg](http://www.global-tek.sg)

### **Shanghai Global-Champion Machinery Co. Ltd**

Tel: + 86 21 5746 9170

Fax: + 86 21 5146 9117

e-mail : [info@global-tek.sg](mailto:info@global-tek.sg)

Website : [www.global-tek.sg](http://www.global-tek.sg)