

INSTRUCTION FOR USE

Model: GT-UIM (C)

Undercounter Glass & Dishwasher

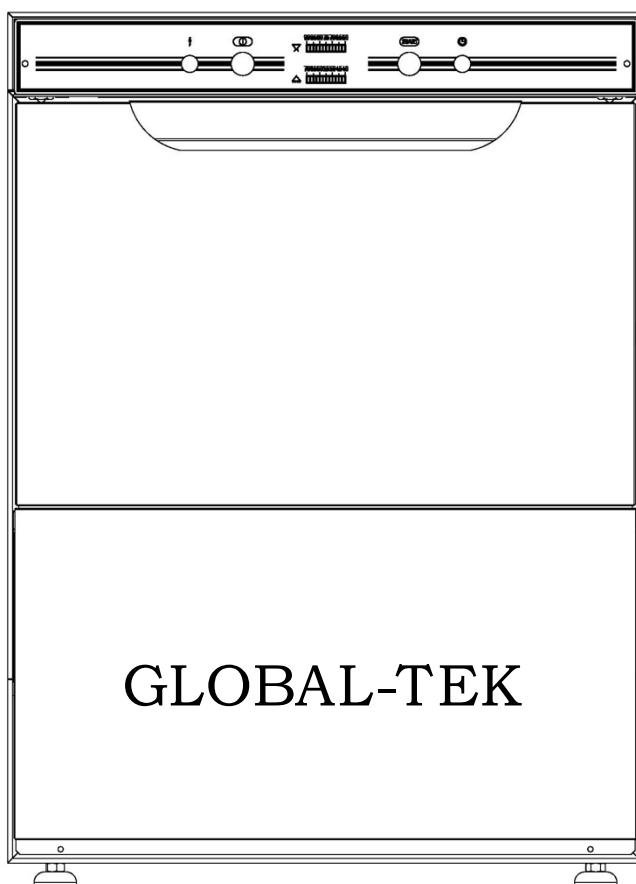

Content

<u>Parts Name</u>	<u>Page</u>
Wash and Rinse System	3-4
Upper Housing	5-6
Wash Tank & Drain Assembly	7-9
Wash Pump & Booster Assembly	10-11
Door Lift	12
Control Panel Assembly	13-14
Door Panel Assembly	15

Wash & Rinse Assembly

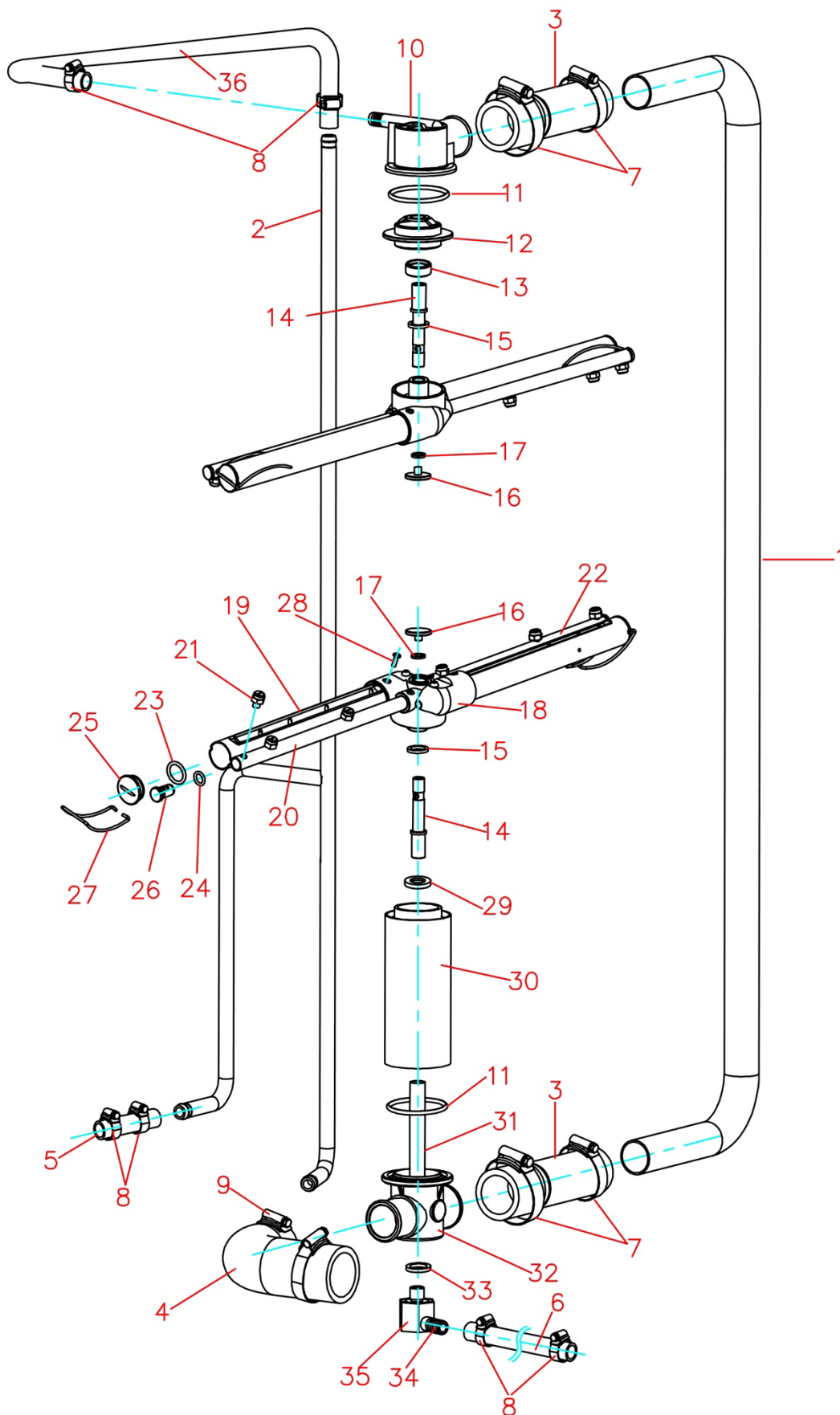

Undercounter Glass & Dish Washer, Model: UIM (C)

Wash and Rinse Assembly

Location	Part No.	Description	Qty
1	0TX-07-6B	Wash Piping Assy (Short 5cm)	1
2	0TX-07-5B	Rinse Piping Assy	1
3	F021-07/4-01	Rubber Hose (IN)	2
4	F021-07/2-01	Rubber Hose (OUT)	1
5	F021-D13-01	Rubber Hose (Up, 90mm)	1
6	F021-D13-01	Rubber Hose (Lower, 280mm)	1
7	E018-32X57-01	Hose Clamp 32-57	4
8	E018-11X25-01	Hose Clamp 11-25	6
9	E018-32X57-01	Hose Clamp 32-57	2
10	F011-05/11/2-01	Upper Manifold	1
10-1	A012-05/11/1-01	Upp Wash Arm Manifold Nut	1
11	F002-02/10-01	O Ring	2
12	A012-05/19-01	Fixed Frame	1
13	A012-05/6-01	Spacer	1
14	A012-05/9-01	Thread Bushing	2
15	F017-05/4-01	Washer	2
16	A012-05/3-01	Lock Screw	2
17	F017-05/10-01	Washer	2
(18-28)	0PJ-TX-QXG	Wash & Rinse Piping Assy	2
18	F011-05/2/6-01	Manifold	2
19	A012-05-2-1	Wash Piping Assy	4
20	A012-05/1/3-01	Rinse Arm	2
21	A012-05/1/2-01	Rinse Nozzle	12
22	A012-05/1/1-01	Rinse Arm	2
23	F002-16X2.65-01	O Ring 16x2.65	4
24	F002-6.9X1.8-01	O Ring 6.9x1.8	4
25	F005-05/2/2-01	Wash Arm End Cap	4
26	F005-05/2/5-01	Rinse Arm End Cap	4
27	A012-05/2/3-01	End Cap Clip	4
28	E001-M4X12-01	Screw M4x12	8
29	A012-05/20-01	Washer	1
30	F038-05/17B-01	Wash Stand Post	1
31	A012-05/7-02	Rinse Inlet Connector	1
32	F011-05/18-01	Lower Manifold	1
33	F001-06/2/2-01	O Ring	1
34	A012-05/8/1-01	Water Inlet Adaptor	1
35	A012-05/8/2-01	Joint holder	1
36	F021-50310/3A-01	Rinse Pump (Out) Connecting Pipe (long)	1

Upper Housing

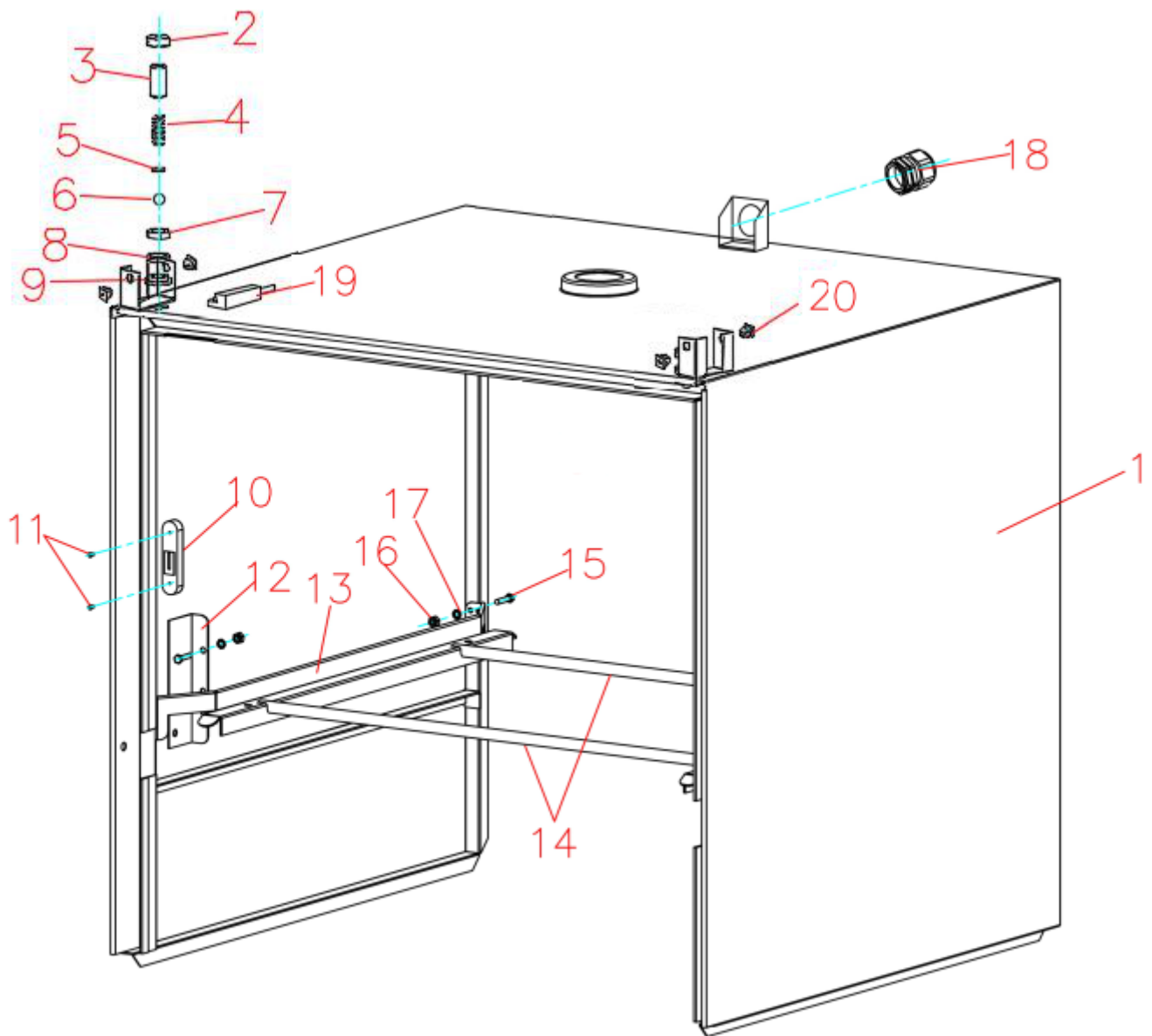

Undercounter Glass & Dish Washer, Model: UIM (C)

Upper Housing

Location	Part No.	Description	Qty
1	0TX-01B	Upper Hood	1
2	A012-06/4/5-01	End Cap	2
3	A012-06/4/1-01	Double-Screw Bolt	2
4	A002-06/4/4-01	Door Spring	2
5	A012-06/4/3-01	Spacer	2
6	A012-06/4/2-01	Ball Bearing	2
7	A012-06/4/6-01	Up Locknut	2
8	A012-06/4/8-01	Washer	2
9	A012-06/4/7-01	Down Locknut	2
10	F018-01/8-01	Slide Block	2
11	E003-M2.9*9.5-01	Sunk Screw M2.9*9.5	4
12	0TX-01-7L	Rail Bracket (left)	1
	0TX-01-7R	Rail Bracket (right)	1
13	0TX-01-5-1A	Rack Rail	2
14	C004-D10-01	Supporting Bar	2
15	E002-M4X12-01	Screw M4x12	10
16	E013-M4-01	Nut M4	10
17	E021-M4-01	Serrated lock Washer M4	10
18	G029-PG21/2-01	29mm Conduit	1
19	0JD-65998A	Magnetic Switch w Cable	1
20	F047-3S-0382-01	Nylon Clip	4
1	0TX-01B	Upper Hood	1

Wash Tank & Drain Assembly

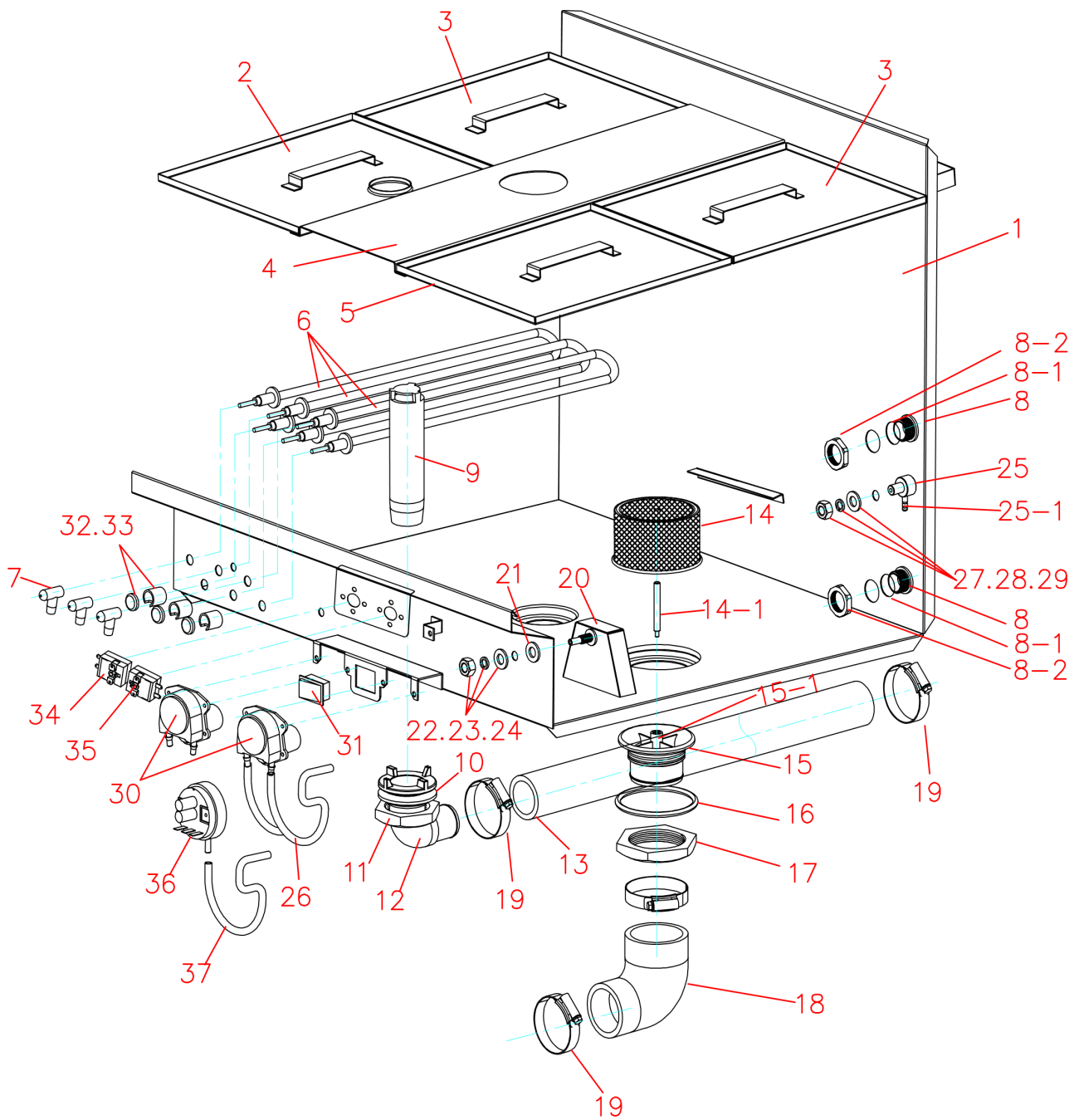

Undercounter Glass & Dish Washer, Model: UIM (C)

Wash Tank & Drain Assembly

Location	Part No.	Description	Qty
1	0TX-01-2B	Wash Pan	1
2	0TX-01-12	Scrap Tray (Front Left)	1
3	0TX-01-14	Scrap Tray (Rear Left & Right)	2
4	0TX-01-10B	Centre Scrap Tray Holder	1
5	0TX-01-13	Scrap Tray (Front Right)	1
6	G005-1KW-03	Tank Heater 1kw, 380V (JRG-3)	3
7	F049-13X27.5X19-01	Protective Rubber Casing	2
8	A012-50320-01	Hole Plug	2
8-1	F002-22X2*65-01	O Ring 22x2.65	2
8-2	A012-50321-01	Nut	2
9	F036-05/15-03	Drain Stopper	1
10	F002-05/14/3-01	Gasket	1
11	F037-05/14/2-01	Nut	1
12	F011-05/14/1-01	Drain Elbow	1
13	F021-DN32X350-01	Drain Pipe 32x350	1
14	A012-06/1/1D-01	Pump Intake Screen	1
14-1	A012-06/1/3A-02	Pump Intake Screen Connector	1
15	F011-05/12/2-01	Water Outlet	1
15-1	A012-05/12/1-01	Nut	1
16	F002-02/8-01	O Ring	1
17	F037-05/13-01	Water Outlet	1
18	F021-07/3-01	Wash Pump Hose (Inlet)	1
19	E018-32X57-01	Hose Clamp 32x57	3
20	0TX-06-2-4	Air Chamber	1
21	F017-2XD8XD16-01	Washer	1
22	E013-M8-01	Nut M8	1
23	E011-M8-01	Spring Washer M8	1
24	E012-M8-01	Flat Washer M8	1
25	A012-06/7/1-01	Adapter Connector	1
25-1	A012-06/7/2-01	Detergent Joint	1
26	F022-D8X4-01	Silicone Tube	1
27	E013-M10-01	Nut M10	3
28	E011-M10-01	Spring Washer M10	1
29	E012-M10-01	Flat Washer M10	3

Undercounter Glass & Dish Washer, Model: UIM (C)

30	G003-DHK/JP24-01	Chemical Pump	2
31	G034-KCD4-01	On/Off Button	1
32	G064-01/11/1-01	Wire Connecting Isolation (Body)	3
33	G064-01/11/2-01	Wire Connecting Isolation (Cab)	3
34	G021-82C-01	Tank Thermostat 82°C	1
35	G021-86C-01	Booster Thermostat 86°C	1
36	G019-52UN008-01	Pressure Switch	1
37	F022-D8X4-01	Silicone Tube	1

Wash Pump & Booster Assembly

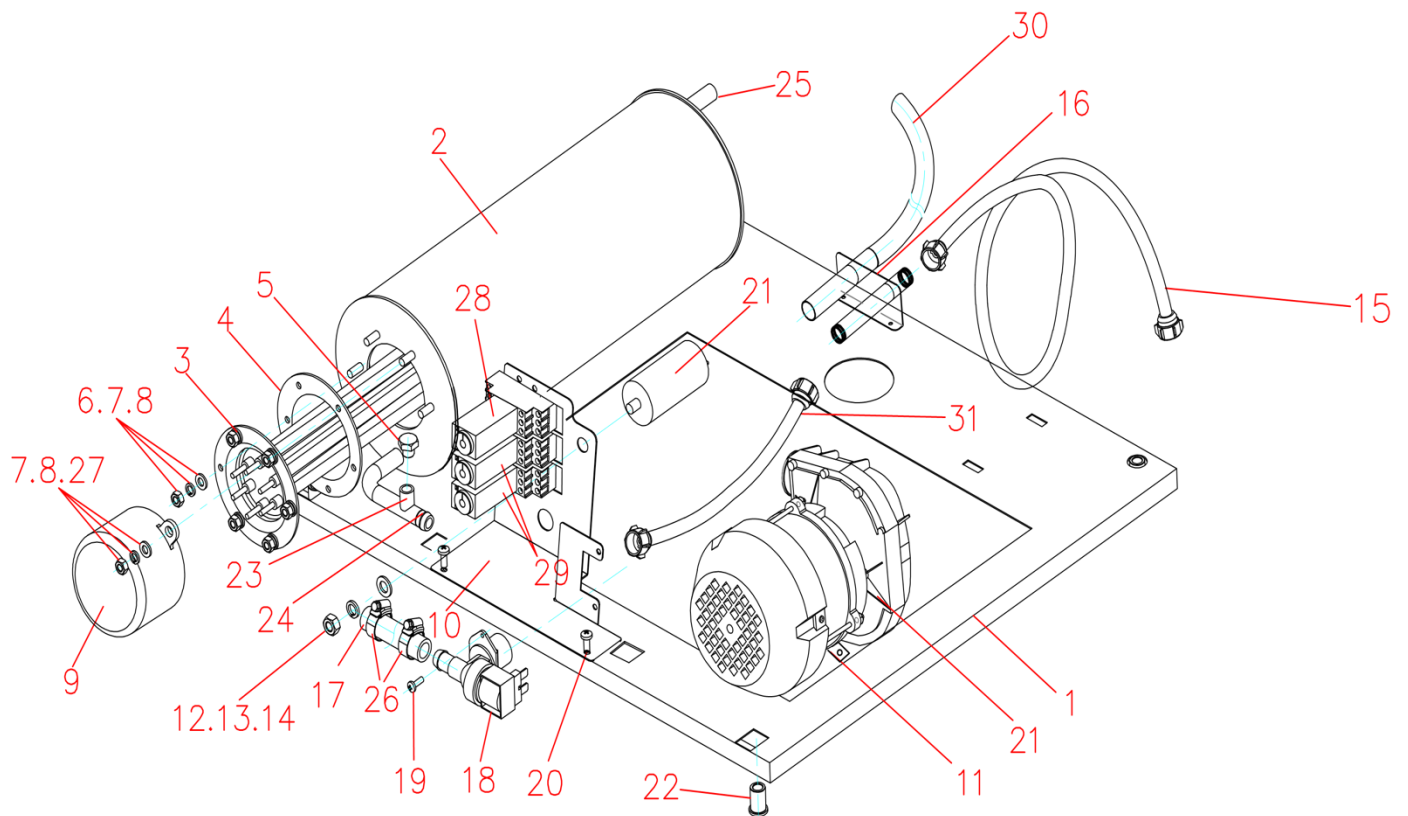

Location	Part No.	Description	Qty
1	0TX-02-2	Base Plate	1
2	0TX-02-4	Booster Tank	1
3	G005-4.5KW-01	Booster Heater 4.5kW	1
4	F001-02/6-01	Heater Gasket	1
5	D035-01	Check Valve (Single)	1
6	E013-M6-02	Nut M6	6
7	E011-M6-01	Spring Washer M6	8
8	E012-M6-01	Flat Washer M6	8
9	F016-TX/02/12-01	Heater Cover	1
10	0TX-02-5-1	S. S Supporting Plate	1
11	0TX-02-5-2	Wash Motor Bracket	1
12	E013-M8-01	Nut M8	1
13	E011-M8-01	Spring Washer M8	1
14	E012-M8-01	Flat Washer M8	1
15	D024-3/4*2M-01	S.S Flexible Hose	1
16	0TX-06-3	Hose Bracket	1
17	F021-D13-01	Rubber Hose 180mm	1
18	G017-220V-01	Solenoid Valve	1
19	E002-M4X12-01	Screw M4x12	8
20	E002-M5X12-01	Screw M5x12	4
21	G003-TX/50-02	Wash Pump	1

Undercounter Glass & Dish Washer, Model: UIM (C)

22	E007-M10-01	Nuts M10	4
23	A012-02/4/6-01	Rinse Aid Injector	1
24	A012-07/5/3-01	Inlet Pipe Joint	1
25	A012-50302/4-01	Hose Connection	1
26	E018-11X25-01	Hose Clip 11x25	2
27	E013-M6-01	Nut M6	2
28	G011-180S/AC220V-02	Timer 180S, 220V (Small)	1
29	G011-10S/AC220V-02	Timer 10S, 220V (Small)	2
30	F043-150-01	Drain Pipe	1
31	D024-3/4X800-01	S.S Inlet Pipe	1

Door Lift

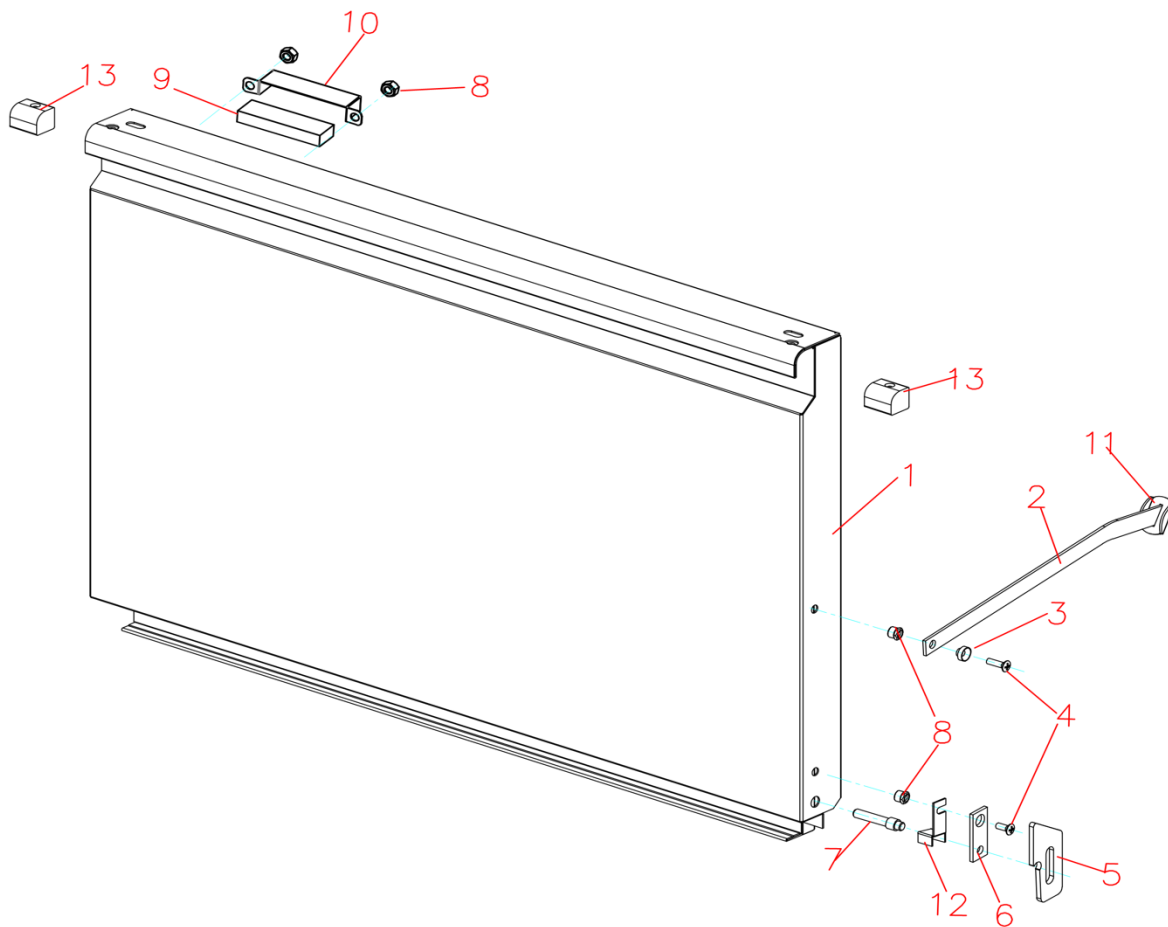

Location	Part No.	Description	Qty
1	0TX-03	Machine Door	1
2	0TX-01-4	Door Draw Bar	2
3	A012-01/4/4-01	Draw Bar Gasket	2
4	E001-M4X12-01	Oval Head Screw M4x12	8
5	F039-03/6-01	Door Clapboard	2
6	0TX-03-4	Door Platen	2
7	A012-01/4/3-01	Door Spindle	2
8	E015-M4-01	Lock Nut M4	6
9	A005-10X17X51-01	Magnet	1
10	0T2D-65318-8A	Magnet Housing	1
11	0TX-01-4-2	Rod Baffle	2
12	0TX-03-7	Door plank of fasteners	2
13	F025-08-01	Anti-hand Block	2
14	E021-M4-01	Serrated lock Washers	2

Control Panel Assembly

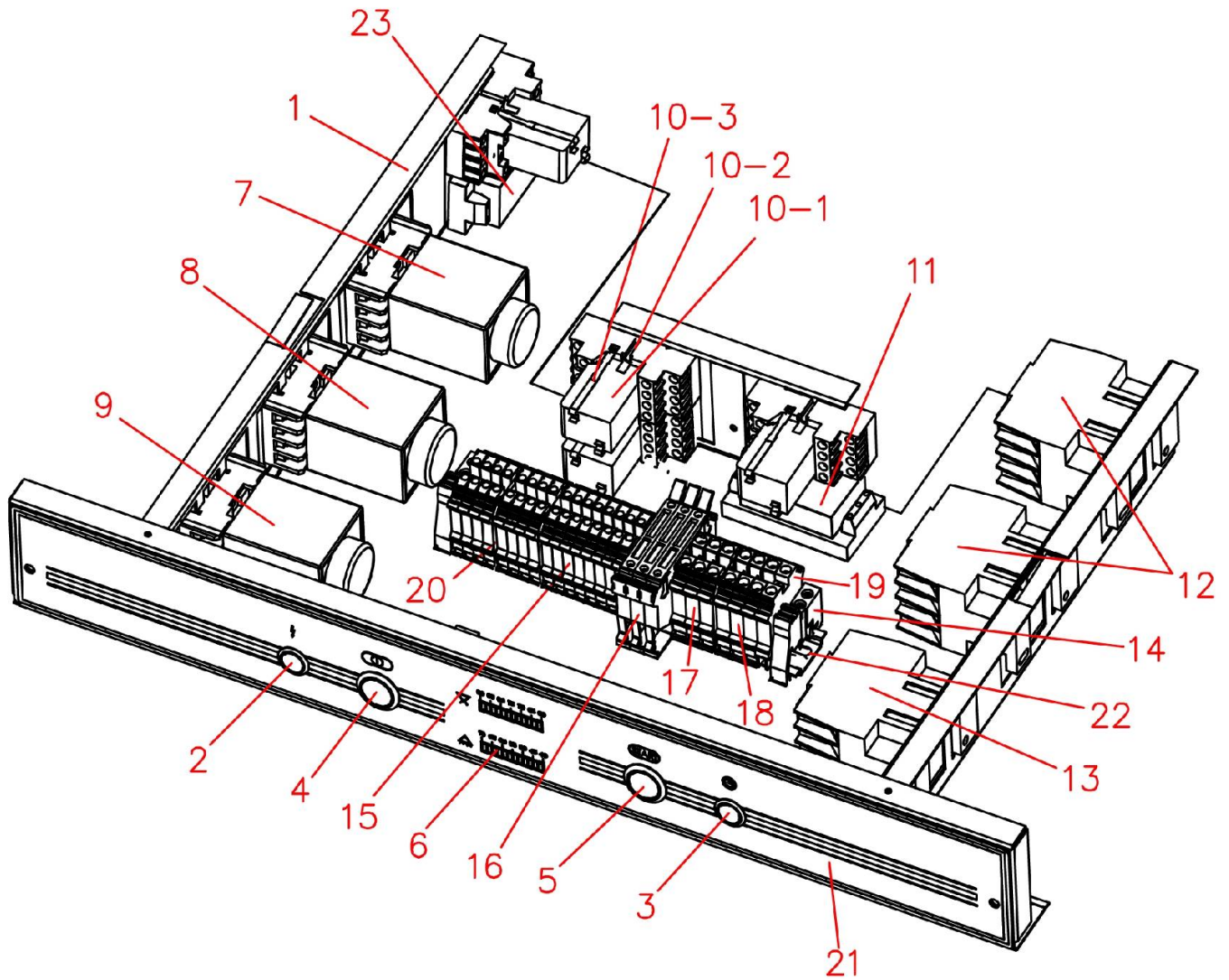

Undercounter Glass & Dish Washer, Model: UIM (C)

Control Panel Assembly

Location	Part No.	Description	Qty
1	0TX-04	Electrical Box	1
2	G035-E/5V-01	Indicator Light (Yellow)	1
3	G035-E/5V-02	Indicator Light (Green)	1
4	G036-11Z-01	On / Off Button	1
5	G036-11/TX-01	Start / Stop Button	1
6	G014-1020-01	Temperature Display Panel	1
7	G011-180S/AC220V-01	Timer 180S, 220V	1
8	G011-10S/AC220V-01	Timer 10S, 220V	1
9	G011-30S/AC220V-01	Timer 30S, 220V	1
10-1	G012-P7-02	Relay 220V	4
10-2	G028-RXZE1M4C-01	Relay Base	4
10-3	G012-RXZ410-01	Relay Clip	8
11	G024-220V/12V-01	Inverter	1
12	G008-E2501M5N-01	Wash & Booster Heater Contactor	2
13	G008-E0610M5N-01	Wash Motor Contactor (50Hz)	1
14	G042-2G2-01	Track Holder	2
15	G041-4-01	Wiring Terminal UKJ-4	17
16	G041-4RD-01	Wiring Terminal UKJ-4RD	3
17	G041-6-01	Wiring Terminal UKJ-6	3
18	G041-6-02	Wiring Terminal UKJ-6 (Blue)	3
19	G041-6JD-01	Wiring Terminal UKJ-6JD	1
20	G032-G/DUK-01	The Protective Plate	5
21	G031-TX-01	Panel Sticker	1
22	G047-DG-01	Guide Rail	0.22
23	G024-220V/5V-03	Inverter	1

Undercounter Glass & Dish Washer, Model: UIM (C)

Door Panel Assembly

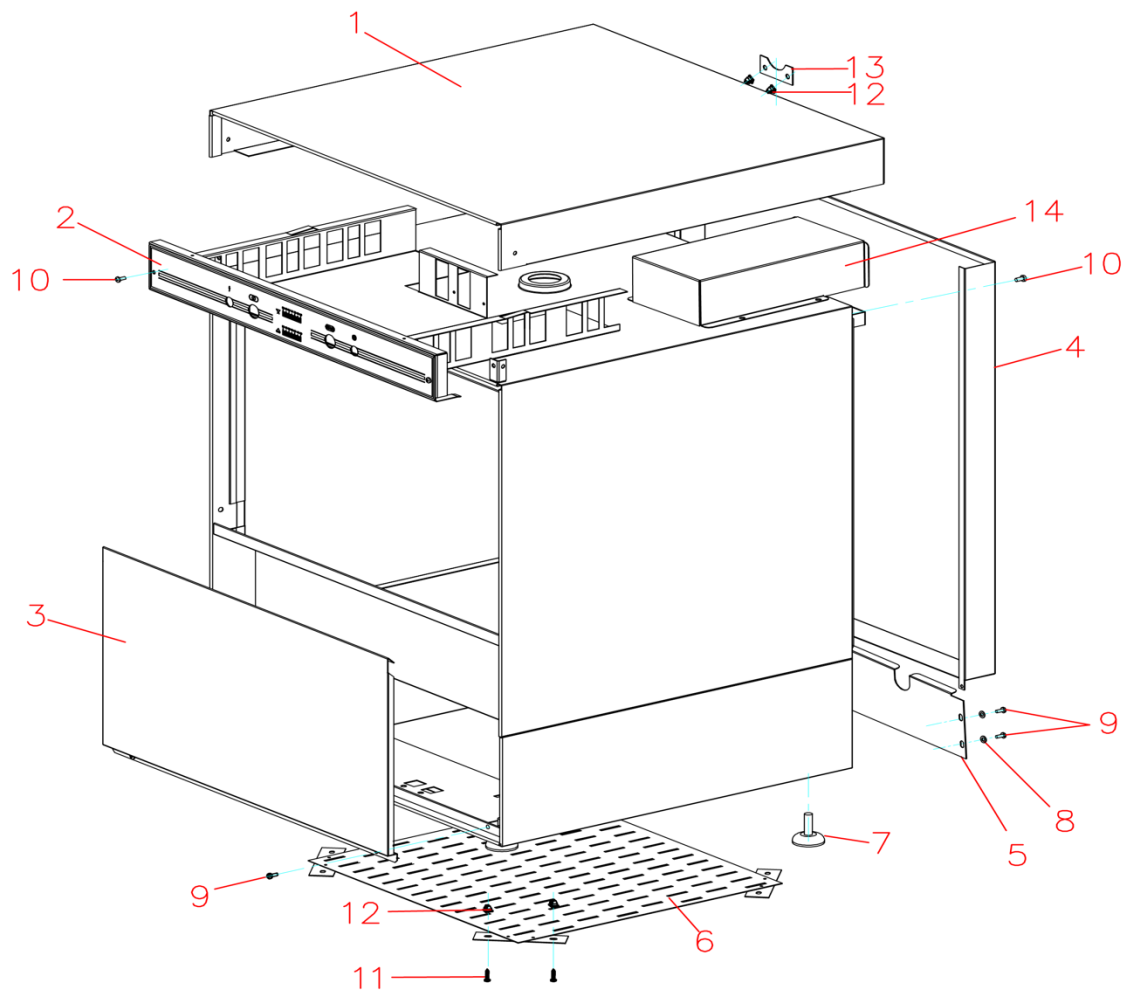

Location	Part No.	Description	Qty
1	0TX-04-1	Top Panel	1
2	0TX-04-3	Panel Sticker Bracket	1
3	0TX-02-3B	Lower Front Panel	1
4	0TX-04-2	Rear Panel	1
5	0TX-04-5A	Lower Rear Panel	1
6	0TX-02-11	Base Plate	1
7	A003-466187-01	Adjustable Leg	4
8	E021-M4-01	Lock Washer M4	4
9	E002-M4x12-01	Screw M4x12	6
10	E002-M5X10-01	Screw M5x10	4
11	E003_ST3.9x19_01	Bolt	8
12	F047-3S-0382-01	Nylon Clip	10
13	0TX-04-11	Panel Stiffener	1
14	0TX-04-3-4	Electrical Protective Cover	1